

ROAD EQUIPMENT > HONEYCOMB PAVERS

Trapezoid honeycomb paver

Especially for the road pavement (verges) we developed the trapezoid honeycomb paver. Due to his special shape this honeycomb paver can be installed in straight lines as well in turns without any use of cotter elements. By the modern slot and key system an ideal connection and an easy installation is guaranteed in every situation. For a maximum of passive road safety the trapezoid honeycomb paver is equipped with acoustic run down knobs. In addition, this paver is equipped with drilling holes for a longitudinal fastening.

» Product features

Trapezoid honeycomb paver

- Dimension 650 x 460 x 65mm
- Mounting dimension 620 x 460 x 65mm
- 12 squared notches
- Weight approx. 14,5kg
- Recycling material
- Black

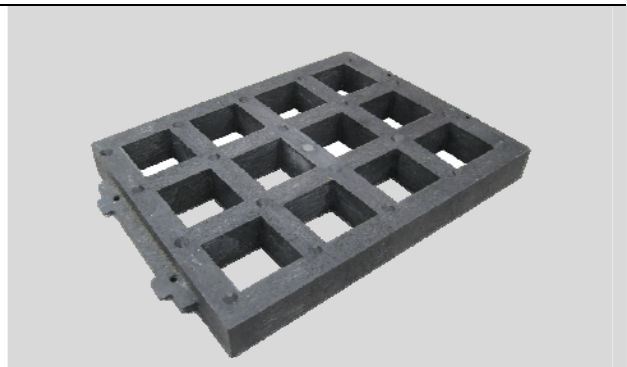

» Your advantages in an overview

- High stability up to 700t/m² on installed area, this means an vehicle weight of approx. 48t by 4 support points (4 wheels)
- Ideal connection by modern slot and key system
- Resistant to oil and acid
- Possible greening on 49%
- Turns in 2° - 4° - steps possible
- Seeping of condensation guaranteed by less sealed surface
- Compressive strength officially certified by TÜV
- Equipped with each 2 drilling holes in the slot and key for a longitudinal fastening
- More passive safety by acoustic run down knobs
- Use of 100% recycled material



Pic. 1 Installation in turns; Pic. 2 Straight line installation

» Technical drawing

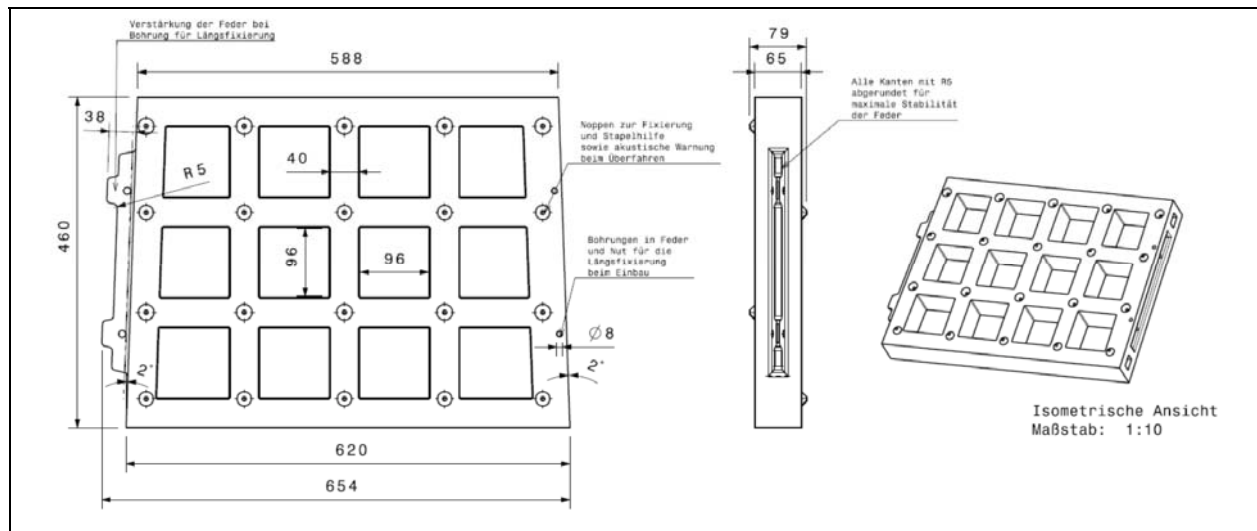

Trapezoid honeycomb paver 650 x 460 x 65mm, single angle 2°, installation circular 4°

» Installation guideline

- On foreseen place tear out soil on desired depth (-580mm)
- Flatten surface and compress with a vibrator
- Fill in wet mix aggregate, flatten and compress
- Fill in grit and compress
- Install the honeycomb paver in foreseen grit
- Backfilling of the paver with grit, soil, humus, gravel
- Sowing (if desired)



More information about our products:
www.beilharz-strasse.de

If you have any questions please contact our team.



Beilharz GmbH & Co. KG, Straßenausrüstungen | Postanschrift Postfach 11 65, D-72187 Vöhringen | Lieferanschrift Rosenfelder Str. 100, D-72189 Vöhringen
 Telefon +49 (0)7454 9588-0 | Telefax +49 (0)7454 9588-99 | E-Mail anfrage@beilharz-strasse.de | Geschäftsführer Dipl.-Ing. (BA) Stefan Beilharz,
 Dipl.-Ing. (FH) Daniela Schweizer | Persönlich haftende Gesellschafterin Beilharz Verwaltungs GmbH, Sitz Vöhringen, Registergericht Stuttgart, HRB 480 661
 Rechtsform Kommanditgesellschaft, Sitz Vöhringen, Registergericht Stuttgart, HRA 480 449 | Ust.-ID-Nr. DE142651980